

# Double End Tube Deburring

Trusted since 1971 by engineers, maintenance, and production leaders

**BurrMaster**

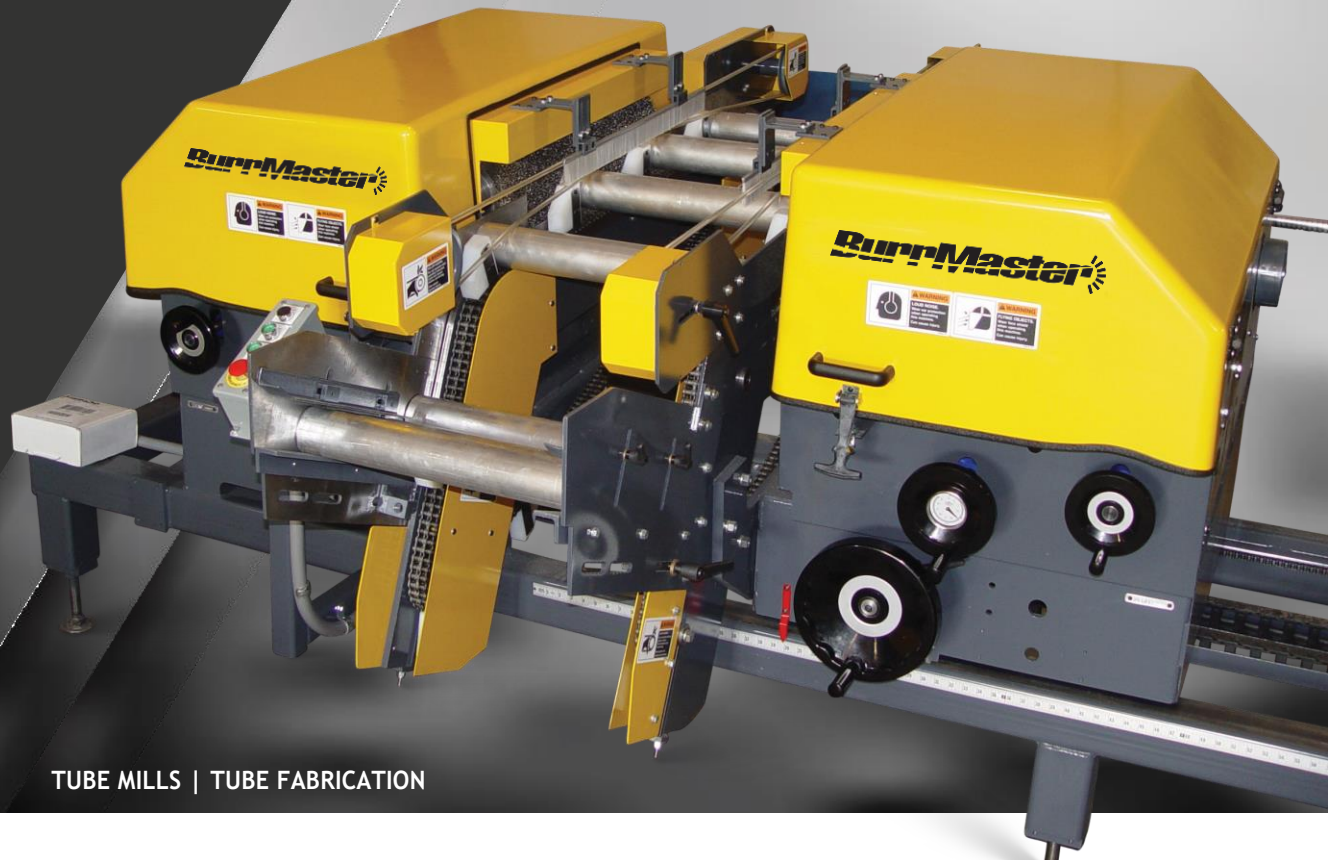

TUBE MILLS | TUBE FABRICATION

THOUSANDS SOLD WORLDWIDE.  
USED BY TUBE MILLS AND  
TUBE FABRICATORS TO DEBURR  
TUBE ENDS FOLLOWING THEIR  
CUTTING PROCESS.

- ▶ Production rates up to 120 pieces per minute quickly and effectively removes burrs
- ▶ Size changes typically done in 2 minutes or less
- ▶ Deburr rounds, shapes, solids, and extrusions



**Kent**



**México**

811-099-7111

<https://kentmex.com>

# Double End Tube Deburring

Automatically and simultaneously removes burrs on the OD and ID of both tube ends. Tube length changeovers typically done in 2 minutes or less.

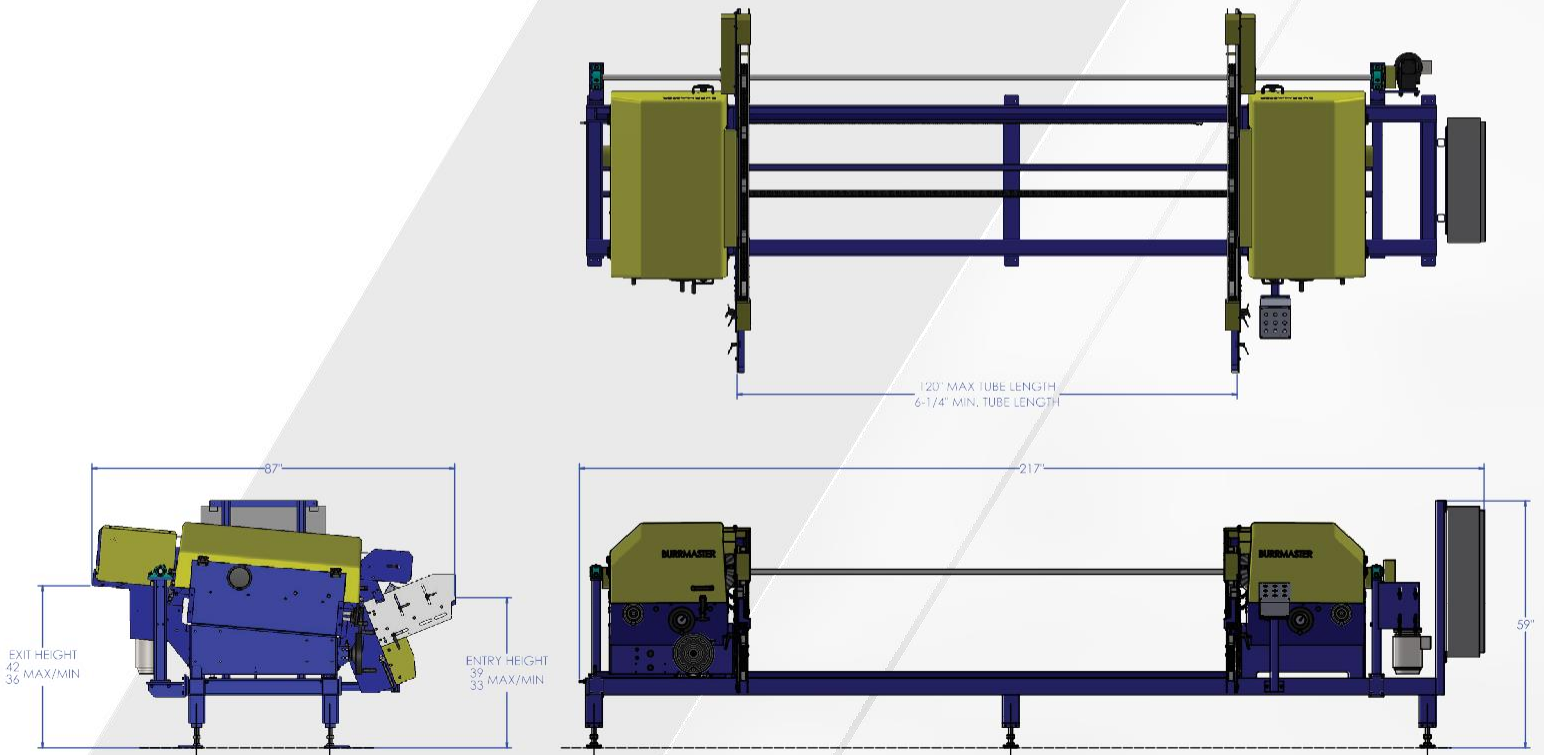

\*DIMENSIONS SHOWN IN INCHES FOR MODEL 2-120

Burrmaster double end deburring machines have one fixed head and one movable head to adjust for length requirements. Easy setup and high production rates allow the machine to be used in-line or off-line as needed.

Burrmaster	Min OD	Max OD	Max Square	Min Length	Max Length	Brush OD	Brush Length
Model 05	0.125"	1.75"	1"	3.75"	120"	12"	12"
Model 05 STR	0.375"	3"	2"	3.75"	120"	12"	18"
Model 8	0.500"	3"	N/A	1.50"	40"	12"	18"
Model 2	0.500"	3.50"	2.50"	6"	120"	12"	24"
Model 2 STR	0.750"	5"	3"	8"	120"	14"	30"
Model 3	1"	6"	4"	10"	120"	16"	42"

\*Machines available to handle custom lengths that do not fall within the standard-length ranges.  
 \*Above sizes are general recommendations, please contact us to discuss your specific application.

- ▶ 12-month warranty
- ▶ Used and refurbished machines available

#### AVAILABLE OPTIONS

- ▶ Full range of brushes available based on your application
- ▶ Bank control to accept tubes automatically from prior process
- ▶ Dust collection system
- ▶ Non-marking features